

HD 10/25 S HD 13/18 S Service Manual



1 Contents

2	Preface	3
3	Safety instructions	3
3.1	Hazard levels	3
4	Technical Features	4
4.1	Drive	4
4.2	Pump	4
4.3	Detergent system	4
4.4	Electrical system	4
4.5	Electronics system	4
4.6	Other features	4
4.7	Field of application	5
4.8	Type plate	5
5	Parts of the system	6
5.1	Front view	6
5.2	View from behind	7
5.3	View from below	8
5.4	Front view (without cover)	9
5.5	Front view (electric box opened)	10
6	Function	11
6.1	Motor/pump unit	11
6.2	Water filter	11
6.3	Pump diagram	12
6.4	Hand spraygun	15
6.5	Pressure and volume regulation	16
6.6	Triple nozzle	17
6.7	Electronics system	18
6.7.1	Pump monitoring	18
6.7.2	Leakage monitoring	18
6.7.3	Motor protection	18
6.7.4	Display	18
6.7.5	Reset	19
6.7.6	Setting the DIP switches	19
6.8	Bypass valve	20
7	Basic settings and service procedures	21
7.1	Adjusting the overflow valve	21
7.2	Trigger gun with servopress pressure regulator	21
7.3	Trigger gun standard	21
7.4	Hose drum	22
7.4.1	Remove the hose drum	22
7.4.2	Uninstall / install high-pressure hose	22
7.4.3	Replace the seal of the rotary grommet	23
8	Troubleshooting	25
9	Technical Documentation	26
9.1	Technical specifications	26
10	Special tools	27
11	Circuit diagram	29
12	Torques	30

2 Preface

Good service work requires extensive and practice-oriented training as well as well-structured training materials. Hence we offer regular basic and advanced training programmes covering the entire product range for all service engineers.

In addition to this, we also prepare service manuals for important appliances - these can be initially used as instruction guides and later on as reference guides.

Apart from this, we also regular information about product enhancements and their servicing.

If you should require supplements, have corrections or questions regarding this document, please address these citing the following subject to:

international-service@de.kaercher.com

Subject: **Fall 119269**

The responsible product specialist will take care of your issue.

Copying and duplication of texts and diagrams as well as third-party access to this information is permitted only with the explicit permission of the company:

Alfred Kärcher GmbH & Co. KG

P O Box 160

D -71349 Winnenden

www.kaercher.com

3 Safety instructions

Service and maintenance tasks may only be performed by qualified and specially trained specialists.

Observe safety information in the chapters!

⚠ DANGER

Prior to all work on the appliance, switch off the appliance and pull the power plug.

Shut off water supply.

Drain off water pressure.

3.1 Hazard levels

⚠ DANGER

For an immediate danger which can lead to severe injuries or death.

⚠ WARNING

For a possibly dangerous situation which could lead to severe injuries or death.

⚠ CAUTION

For a possibly dangerous situation which can lead to minor injuries or property damage.

ATTENTION

Pointer to a possibly dangerous situation, which can lead to property damage.

Note

Indicates useful tips and important information.

4 Technical Features

These AC devices are the new top models among the mobile high-pressure cleaners of the super-class devices. Their compact and vertical design allows easy handling and space-saving storage.

4.1 Drive

4-pin, electro motor	Cooling	rpm	Voltage/current type
HD 10/25 S/SX	Water-cooled	1500	400 V / 3~ / 50 Hz
HD 13/18 S/SX	Water-cooled	1500	400 V / 3~ / 50 Hz

4.2 Pump

- 3 piston axial pump, piston with ceramic coating
- Cylinder head and water inlet made of brass
- High-pressure and suction valves made of stainless steel
- Direct shutoff with closed gun via pressure switch control
- Overflow valve for pressure and quantity regulation
- Control injector
- Pressure holding valve
- Manometer

4.3 Detergent system

- Detergent injector
- Detergent check valve
- Detergent dosing valve on the cover of the detergent tank.

4.4 Electrical system

- Power switch without overload protection
- Winding protection contact
- The pressure switch switches an additional contactor that breaks all 3 phases of the power supply

Note

Thanks to the additional contactor, the service life of the pressure switch is extended significantly.

4.5 Electronics system

- Automatic safety switch-off after 30 minutes of non-operation
- Automatic safety switch-off in case of leakage
- Protection against running on 2 phases
- Protection against over and low voltage
- Operating display (LED) for displaying operating states and malfunctions

4.6 Other features

- Softgrip-EasyPress gun with improved ergonomics
- Highest operating comfort thanks to improved, continuous pressure and water volume regulation
- Servopress rotary regulator with ceramic insert
- Integrated water filter with 100 µm mesh for the protection of the pump
- Good mobility on stairs thanks to large full rubber wheels (Ø 300 mm)
- Easy oil level check from the outside, without removal of the casing cover

4.7 Field of application

This service manual describes the following appliances:

Appliance type	Appliance no.
HD 10/25 S	1.286-120.0
HD 10/25 SX	1.286-500.0
HD 13/18 S	1.292-100.0
HD 13/18 SX	1.292-500.0

4.8 Type plate

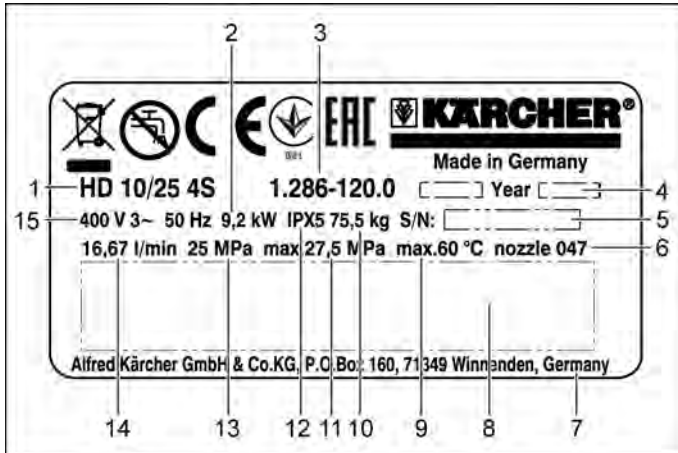

The type plate is located on the rear of the appliance.

- 1 Appliance description
- 2 Connected load
- 3 Part number
- 4 Year of manufacture
- 5 Serial number
- 6 Nozzle size
- 7 Address of manufacturer
- 8 Bar code. Contains part and serial number.
- 9 Max. feed temperature
- 10 Typical operating weight
- 11 Max. operating over-pressure
- 12 Type of protection
- 13 Working pressure
- 14 Flow rate
- 15 Main Supply

5 Parts of the system

5.1 Front view



- | | | | | |
|----|--|-------|----|----------------------------------|
| 1 | Mains plug | | 11 | Lock trigger gun |
| 2 | Mains connection | | 12 | Trigger gun |
| 3 | Water connection | | 13 | Lever for trigger gun |
| 4 | Oil level indicator | | 14 | High pressure hose |
| 5 | Power switch | Q1/S1 | 15 | Spray lance |
| 6 | Operating display (LED) | D1 | 16 | Manometer |
| 7 | Screw of the cover | | 17 | High pressure connection |
| 8 | Storage, power cord | | 18 | Triple nozzle |
| 9 | Transport handle | | 19 | Connection of high pressure hose |
| 10 | Power press regulator
Pressure/ quantity regulation | | | |

5.2 View from behind

Unit without hose drum



- 1 Storage, power cord
- 2 Storage dirt grinder
- 3 Storage triple nozzle
- 4 Kick plate to tilt the appliance
- 5 Wheel
- 6 Storage compartment for accessories
- 7 Detergent tank lid
- 8 Transport handle

Device with hose drum



- 1 Crank, hose drum
- 2 Hose drum
- 3 Storage dirt grinder
- 4 Storage triple nozzle
- 5 Wheel
- 6 Kick plate to tilt the appliance
- 7 Storage compartment for accessories
- 8 Detergent tank lid
- 9 Transport handle

5.3 View from below

Unit without hose drum

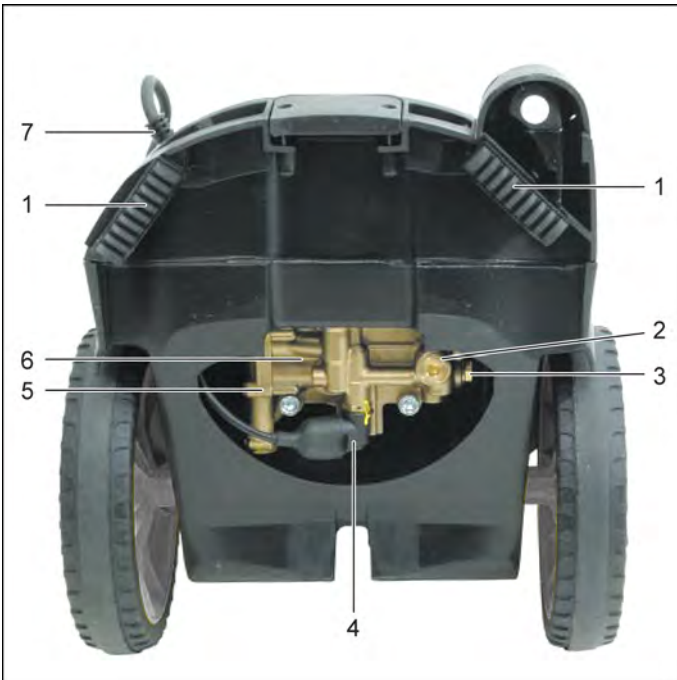

- 1 Rubber feet
- 2 Screw plug pressure retaining valve
- 3 Locking screw for pressure valve
- 4 Pressure switch
- 5 Lid of water supply
- 6 Pump head
- 7 Mains connection

Q2

Device with hose drum

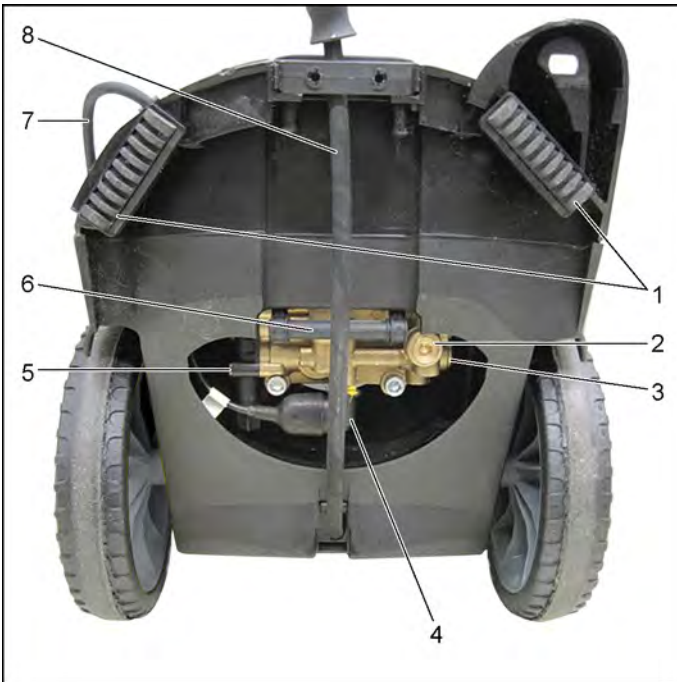

- 1 Rubber feet
- 2 Screw plug pressure retaining valve
- 3 Locking screw for pressure valve
- 4 Pressure switch
- 5 Lid of water supply
- 6 Pump head
- 7 Mains connection
- 8 High pressure hose

Q2

5.4 Front view (without cover)

Unit without hose drum

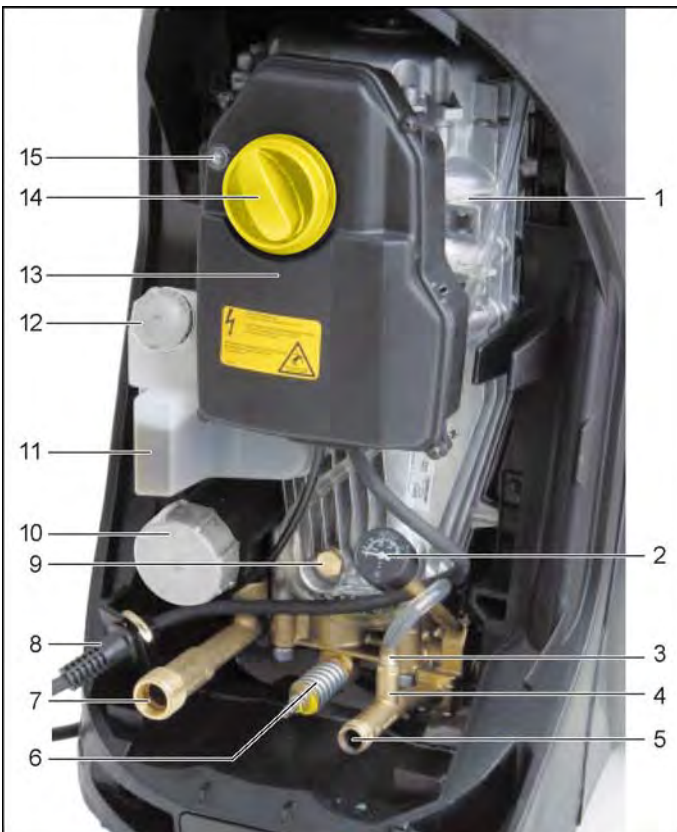

- 1 Motor
- 2 Manometer
- 3 Detergent connection with check valve
- 4 Detergent injector
- 5 High pressure connection
- 6 Overflow valve
- 7 Water connection
- 8 Mains connection
- 9 Oil drain screw
- 10 Water filter
- 11 Oil tank
- 12 Oil container lid
- 13 Electronics system
- 14 Power switch
- 15 Operating display (LED)

M1

Q1/S1
D1

Device with hose drum

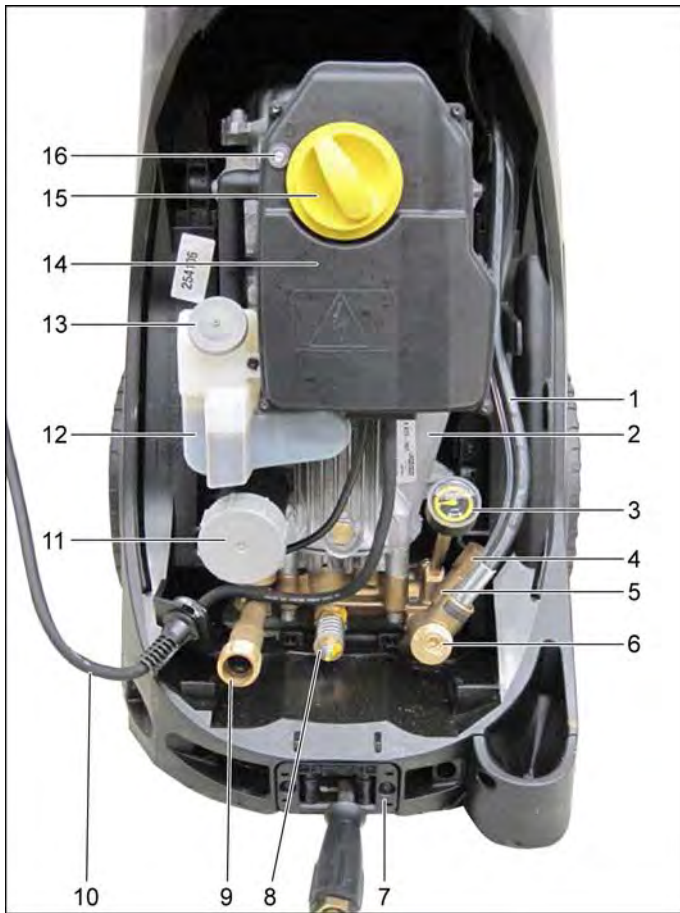

- | | | |
|----|---|-------|
| 1 | High-pressure hose from the pump to the hose reel | |
| 2 | Motor | M1 |
| 3 | Manometer | |
| 4 | Detergent connection with check valve | |
| 5 | Detergent injector | |
| 6 | Bypass valve | |
| 7 | Duct high-pressure hose | |
| 8 | Overflow valve | |
| 9 | Water connection | |
| 10 | Mains connection | |
| 11 | Water filter | |
| 12 | Oil tank | |
| 13 | Oil container lid | |
| 14 | Electronics system | |
| 15 | Power switch | Q1/S1 |
| 16 | Operating display (LED) | D1 |

5.5 Front view (electric box opened)

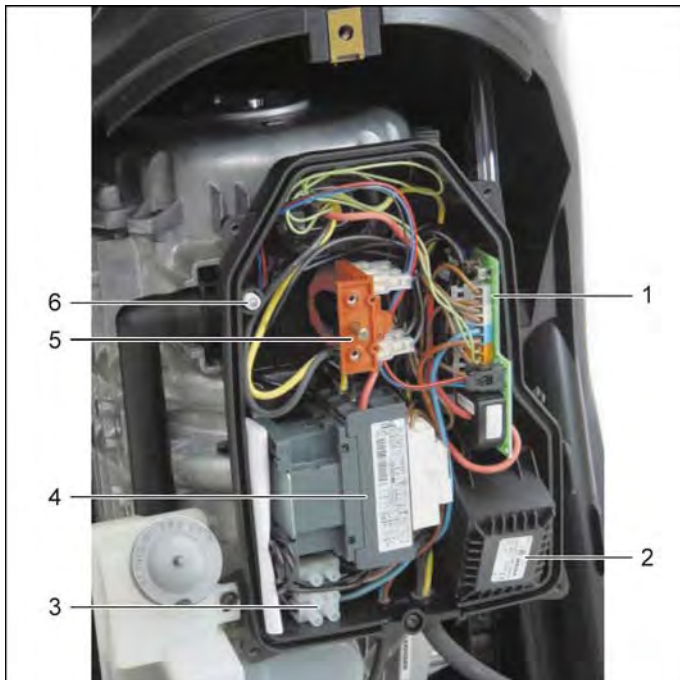

- | | | |
|---|-------------------------|-------|
| 1 | Control chip | A1 |
| 2 | Transformer | T1 |
| 3 | Cable clamp | |
| 4 | Contactor | K1 |
| 5 | Power switch | Q1/S1 |
| 6 | Operating display (LED) | D1 |

6 Function

6.1 Motor/pump unit

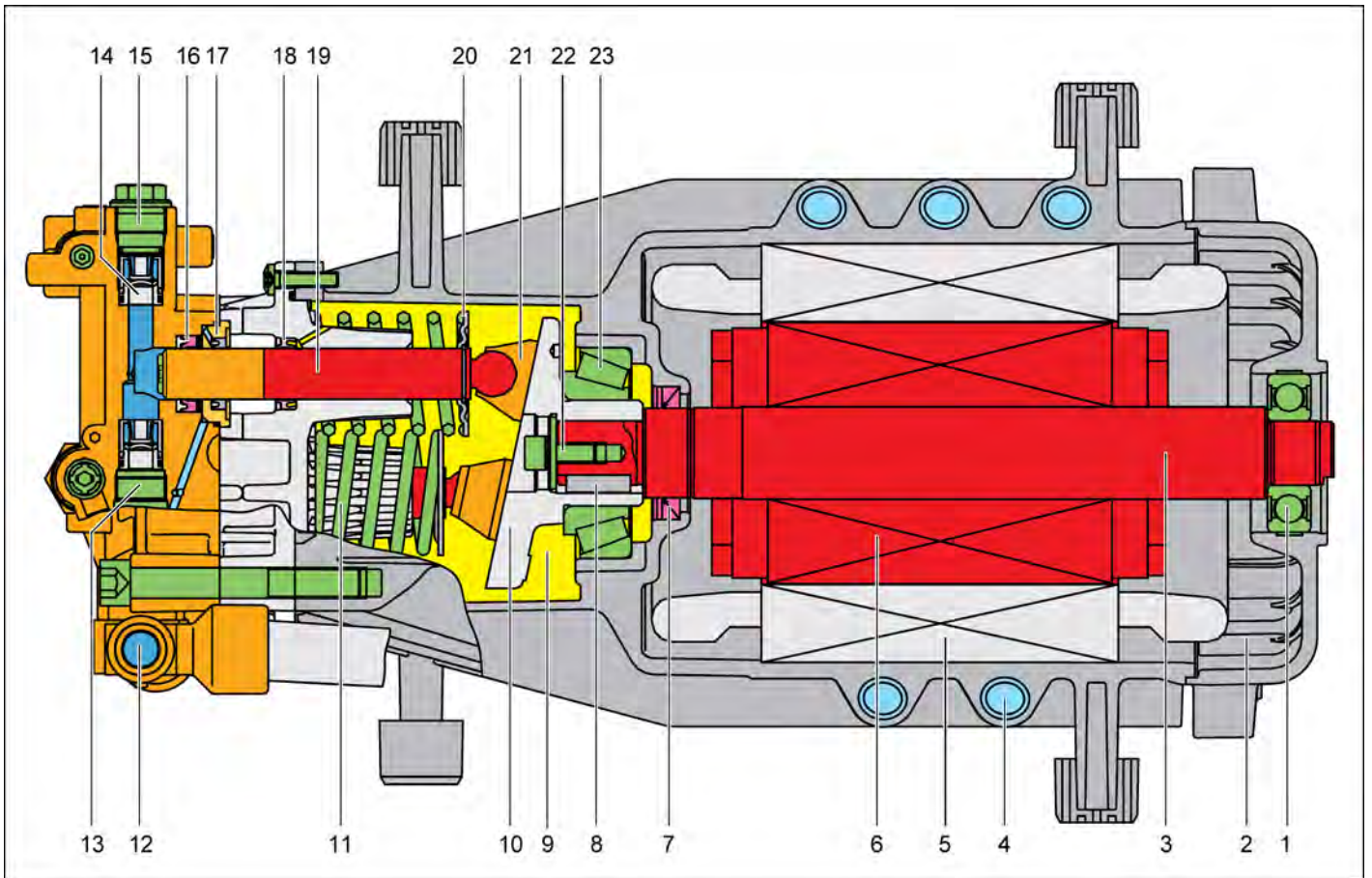

- | | |
|--|-------------------------------------|
| 1 Motor bearing | 13 Suction valve |
| 2 Motor cover | 14 Pressure valve |
| 3 Motor shaft | 15 Locking screw for pressure valve |
| 4 Water cooling | 16 High pressure seal |
| 5 Stator | 17 Low pressure seal |
| 6 Rotor | 18 Oil seal |
| 7 Shaft seal ring | 19 Plunger |
| 8 Fitting key | 20 Holding plate of piston spring |
| 9 Oil bath | 21 Slide shoe |
| 10 Swash plate | 22 Fastening screw, swash plate |
| 11 Piston spring | 23 Motor bearing |
| 12 Screw plug pressure retaining valve | |

6.2 Water filter

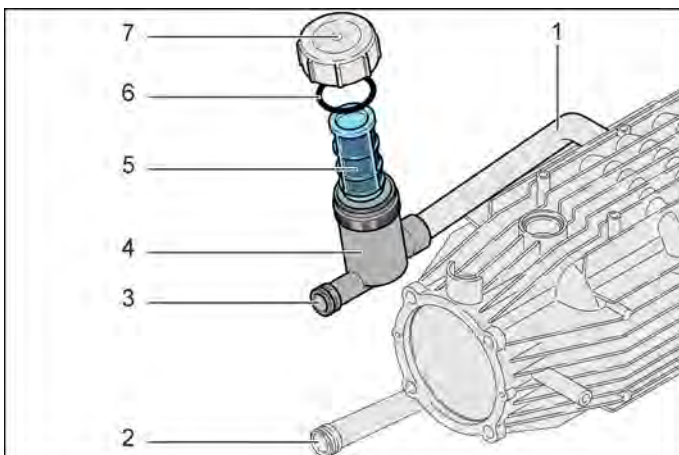

- | |
|------------------------|
| 1 Supply motor cooling |
| 2 Supply pump |
| 3 Supply water filter |
| 4 Filter casing |
| 5 Water filter |
| 6 Washer ring |
| 7 Cap |

6.3 Pump diagram

Trigger gun and servopress rotary regulator opened:

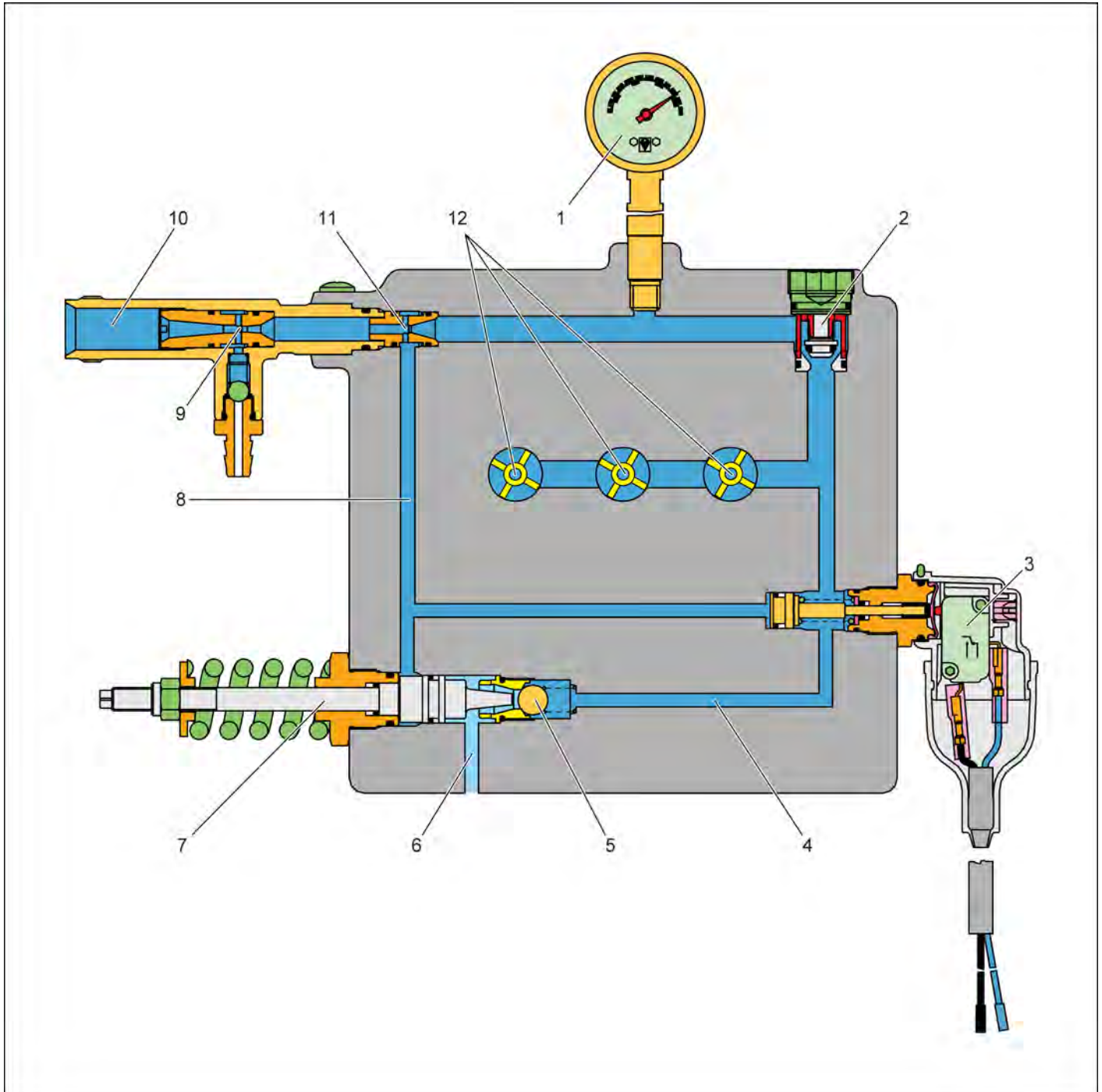

- 1 Manometer
- 2 Pressure holding valve
- 3 Pressure switch
- 4 Connecting boring to overflow valve
- 5 Overflow valve ball
- 6 Connecting boring to suction room
- 7 Piston rod
- 8 Connecting boring from the overflow valve to the control pressure injector
- 9 Detergent injector
- 10 High pressure outlet
- 11 Control pressure injector
- 12 Pressure room with pressure valves

B1

When the power press regulator is opened all the way, the water flows from the pressure room through the pressure holding valve via the control pressure injector to the high pressure outlet.

The ball of the overflow valve is pressed onto the valve seat by the pump pressure and thus seals the connecting boring to the suction chamber.

The manometer displays the working pressure in the pressure room.

But, due to the affect of the control pressure injector, there is less pressure in the connecting boring.

Servopress rotary regulator partially closed:

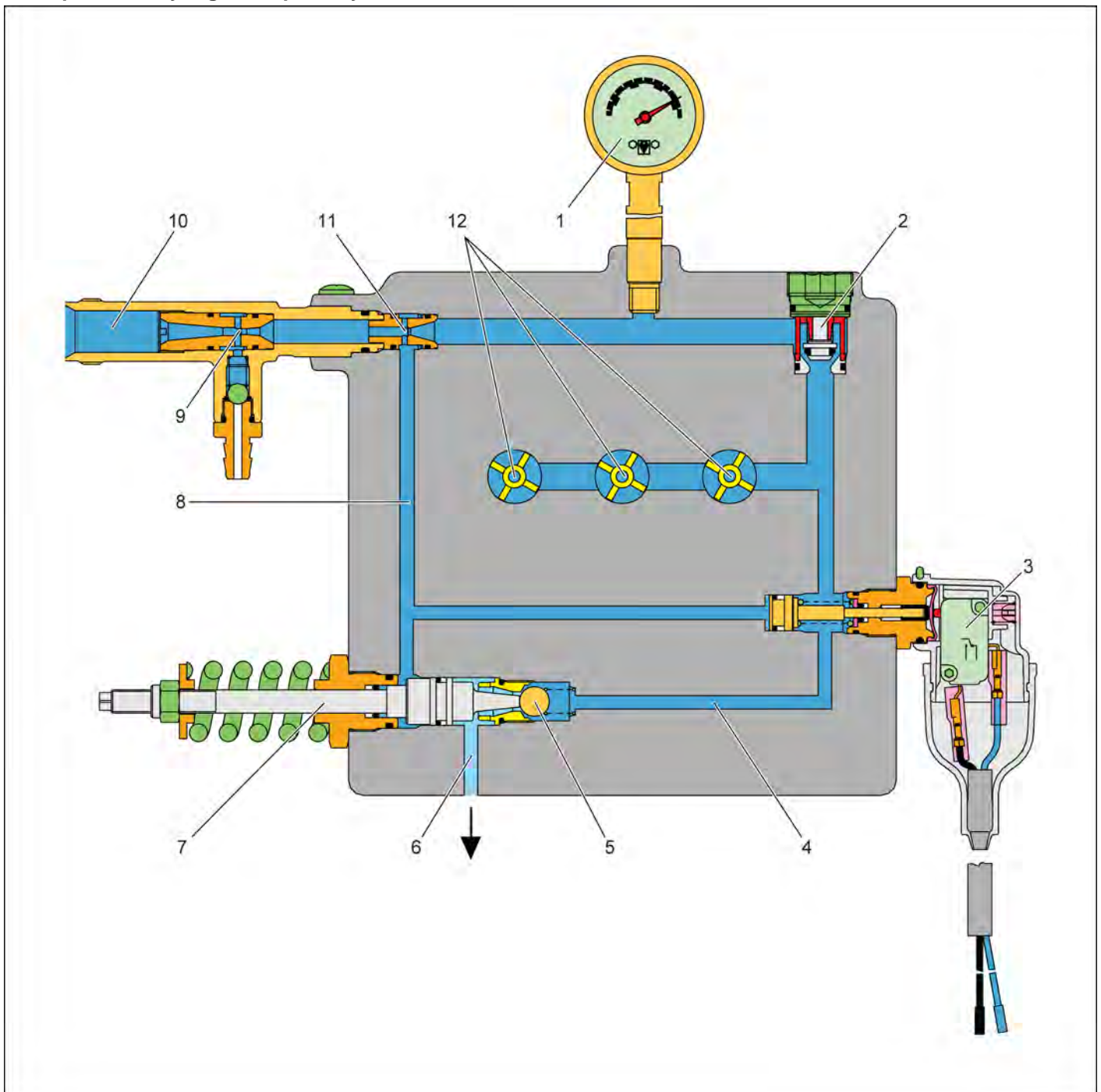

- 1 Manometer
- 2 Pressure holding valve
- 3 Pressure switch
- 4 Connecting boring to overflow valve
- 5 Overflow valve ball
- 6 Connecting boring to suction room
- 7 Piston rod
- 8 Connecting boring from the overflow valve to the control pressure injector
- 9 Detergent injector
- 10 High pressure outlet
- 11 Control pressure injector
- 12 Pressure room with pressure valves

B1

With the power press regulator partially closed, the pressure in the pressure room will not rise any further. However, due to less water volume, the effect of the control pressure injector decreases, so that the pressure in the connecting boring rises. Thus, the piston rod is pressed slightly to the right against the spring pressure. The cone tip of the rod slightly pushes the ball out of its seat so that a part of the flow rate flows to the suction chamber. The pressure switch is slightly pushed to the right due to the increased pressure in the connecting boring, but not far enough to switch off the pressure switch.

Trigger gun closed:

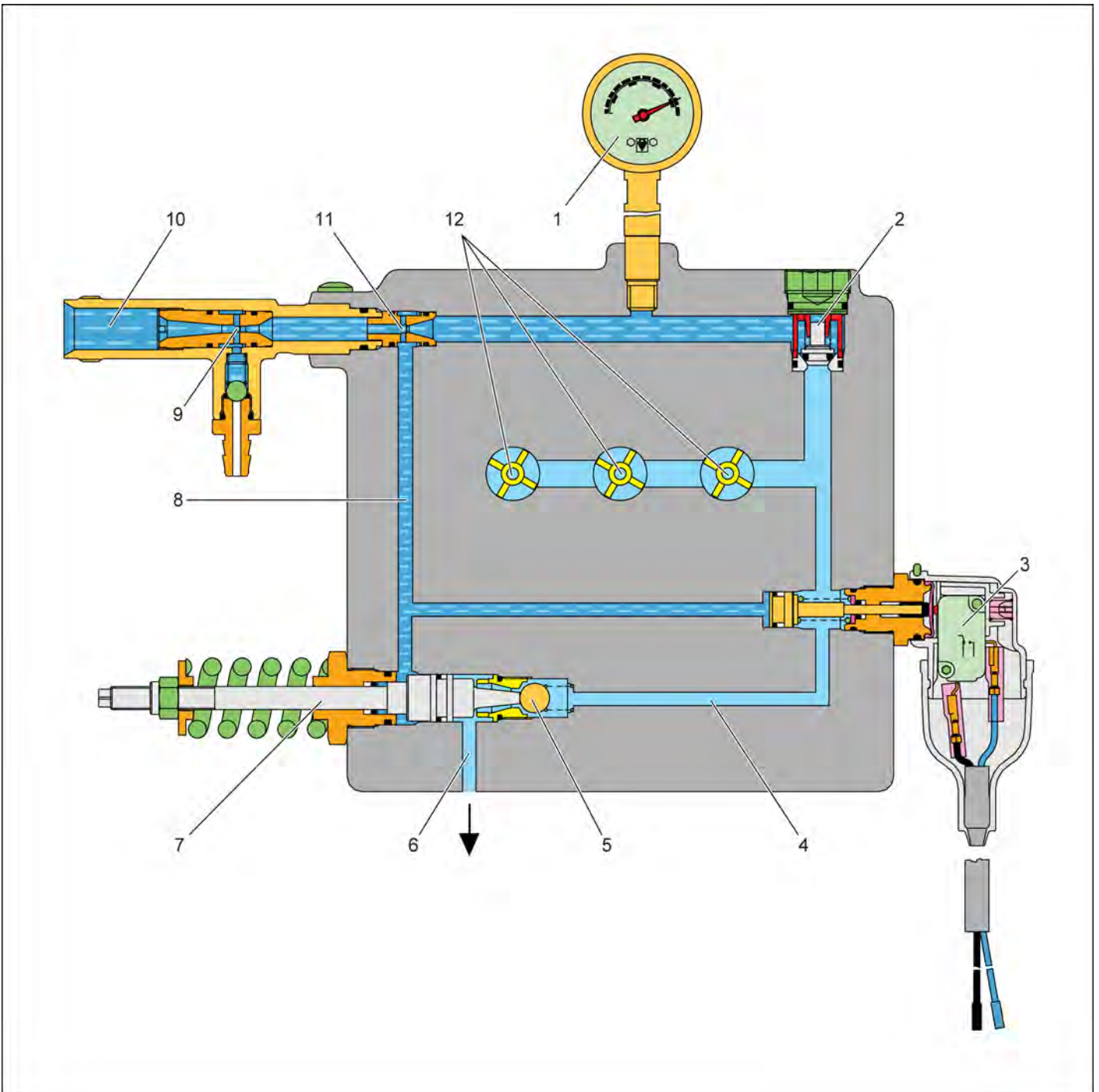

- 1 Manometer
- 2 Pressure holding valve
- 3 Pressure switch
- 4 Connecting boring to overflow valve
- 5 Overflow valve ball
- 6 Connecting boring to suction room
- 7 Piston rod
- 8 Connecting boring from the overflow valve to the control pressure injector
- 9 Detergent injector
- 10 High pressure outlet
- 11 Control pressure injector
- 12 Pressure room with pressure valves

B1

Upon closing the trigger gun, the pressure in the pressure room rises abruptly. This pressure peak will affect the piston rod and the pressure switch via the connecting boring. The ball is pressed out of its seat by the piston rod and the entire flow volume can flow to the suction room via the connecting boring. The pressure switch switches the motor off. As soon as the trigger gun is closed, the pressure retaining valve closes. This way the entire system pressure is locked between the trigger gun and the pressure retaining valve. When the gun is opened again, the pressure in the system decreases rapidly, the overflow valve returns to its original position and the pressure switch switches the motor back on.

6.4 Hand spraygun

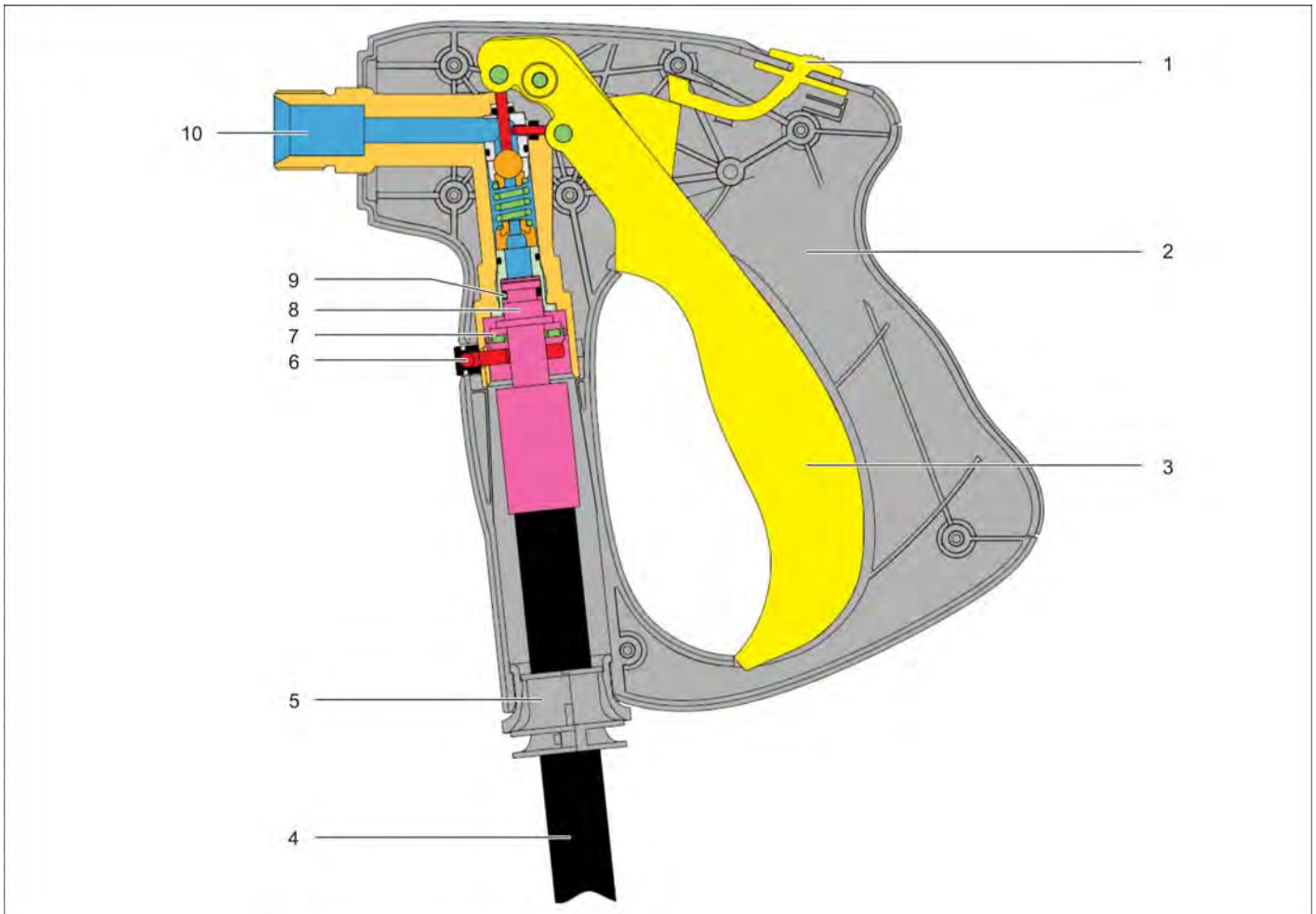

- 1 Lock trigger gun
- 2 Casing shell
- 3 Hand lever
- 4 High pressure hose
- 5 Hose guide
- 6 Safety clip
- 7 Needle bearing
- 8 Coupling high-pressure hose/trigger gun
- 9 O ring
- 10 Node piece

Function

When the manual lever is actuated, the valve in the node piece opens and the water can flow from the hose through the gun into the spray lance.

Note

The node piece cannot be repaired and must be replaced as a complete unit.

The date of manufacture is imprinted on the node piece. It is composed of the month (letters A to L for January through December) and year (1-digit number 1 for 2011, 2 for 2012, etc.).

Example: H1 = August 2011

6.5 Pressure and volume regulation

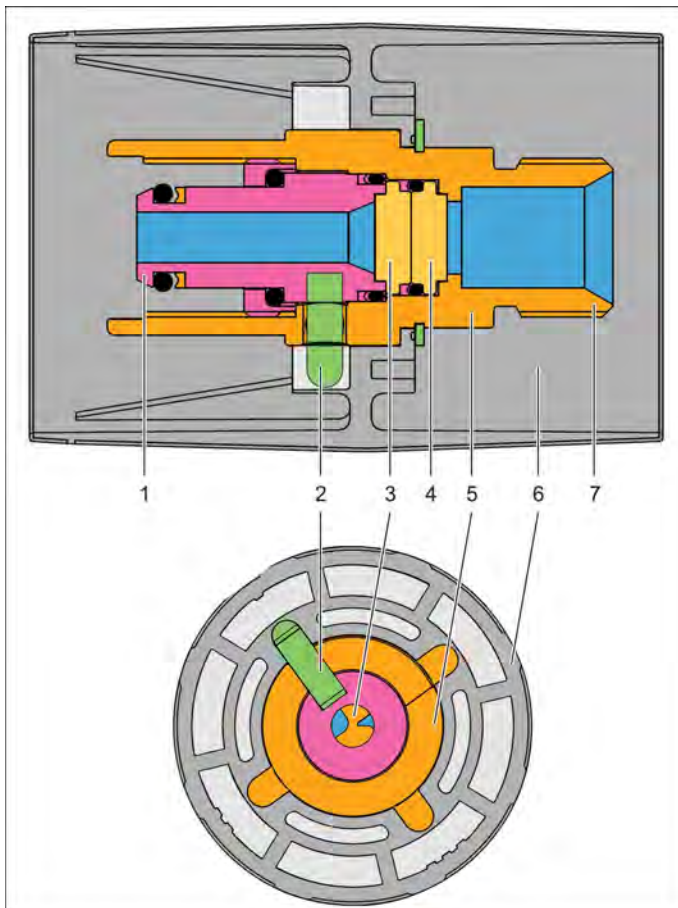

- 1 Connection trigger gun
- 2 Connecting pin
- 3 Ceramic disc on gun side
- 4 Ceramic disc on spray pipe side
- 5 Casing of rotating regulator
- 6 Handle of rotary regulator
- 7 Spray lance connection

The pressure and volume regulation is designed as a rotary regulator between the trigger gun and the spray lance. There are two ceramic discs within the high pressure channel.

The ceramic disc is rigidly connected with the connection of the trigger gun. The ceramic disc is connected to the rotary switch and therefore adjustable. Offset holes in the ceramic discs can adjust the flow volume and the pressure when rotating the discs.

This illustration shows the two overlapping ceramic discs and the water flow (blue) with different opening angles (from 0° to 90°).

With the minimal setting, the water flows through a small hose in the middle of the ceramic discs.

Water flow with opening angle 0° - 90°

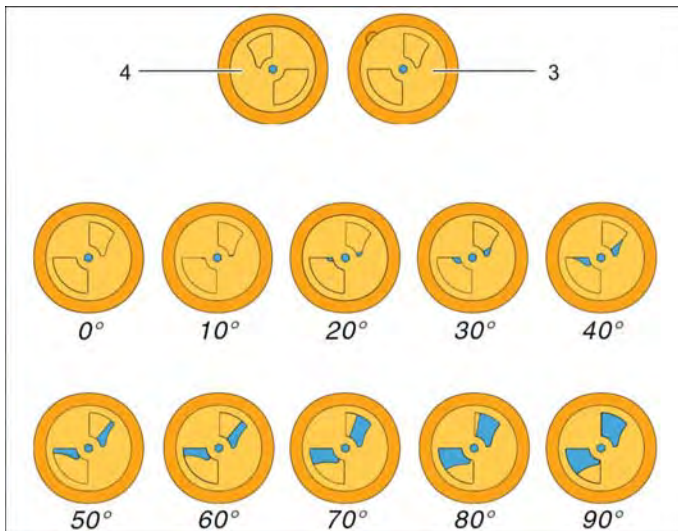

6.6 Triple nozzle



- A Position point jet
- B Initial position
- C Position flat stream

Function

The triple nozzle has two adjustable positions. By rotating the nozzle head, you can switch between the chemicals nozzle (low pressure) and the high-pressure nozzles.

The selection between spotlight nozzle and the flat jet nozzle is done by turning the spray lance while the hand lever of the trigger gun is released.

In the process, the valve ball rolls in front of one of the two nozzles and closes it.

To adjust the point jet, hold the trigger gun in the initial position and turn the handle to the left. Turn the handle to the right for the flat stream.

The valve ball is kept in the selected position by the pressure during work.

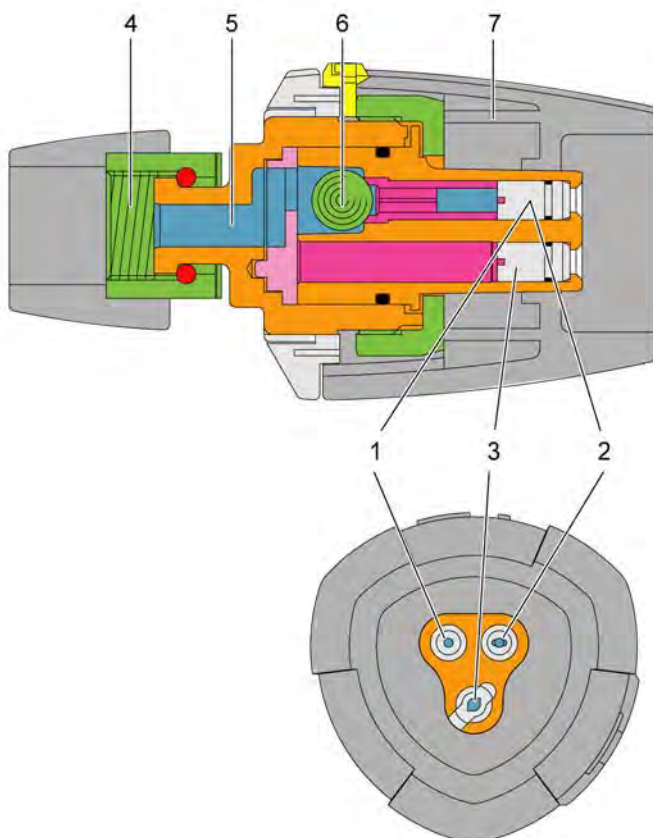

- 1 Detail nozzle
High pressure
- 2 Flat jet nozzle
High pressure
- 3 Chemicals nozzle (low pressure)
- 4 Spray pipe connection
- 5 High pressure channel
- 6 Valve ball
- 7 Adjustable nozzle head

6.7 Electronics system

The device is equipped with a control and monitoring electronic system that monitors a number of functions.

6.7.1 Pump monitoring

In case of a continuous operation or a continuous break of 30 minutes, the immediate switch-off and locking of the device takes place.

Moreover, a visual signal is issued via the operating display (LED).

Both functions can be deactivated by means of the DIP switch (see circuit diagram).

6.7.2 Leakage monitoring

The system checks the device for leaks by monitoring the pressure switch. If the pressure switch opens twice within 2 seconds and this recurs 10 times within 10 minutes, the immediate switch-off and locking of the device takes place. Moreover, a visual signal is issued via the operating display (LED).

This function can be deactivated by means of the DIP switch (see circuit diagram).

6.7.3 Motor protection

If one phase fails, in case of excessive temperature, low voltage or in case of a voltage difference between 2 phases > 50 V, the immediate switch-off and locking of the device takes place.

Moreover, a visual signal is issued via the operating display (LED).

The excess temperature may occur due to the following reasons:

- Over or low voltage
- Overload
- Poor motor cooling (water shortage or high temperature of the cooling water)

6.7.4 Display

Operating display:

LED illuminates green	Operation in order
LED blinks green	Disconnection from the mains (time-out)

Error message:

LED is red	Contact or pressure switch not in order
LED blinks red once	Leak
LED blinks red twice	Winding protection contact was triggered
LED blinks red three times	Power supply
LED blinks red four times	Power consumption is too high End motor blockade

6.7.5 Reset

The resetting of the system in case of faults takes place by switching on and off the power switch.

6.7.6 Setting the DIP switches

	ON	OFF
1	1-phase device	3-phase device
2	Do not use	No after run of the pump
3	Leakage monitoring	No monitoring
4	30 minutes switch-off continuous operation / continuous pause	No switch-off

6.8 Bypass valve

Device with hose drum

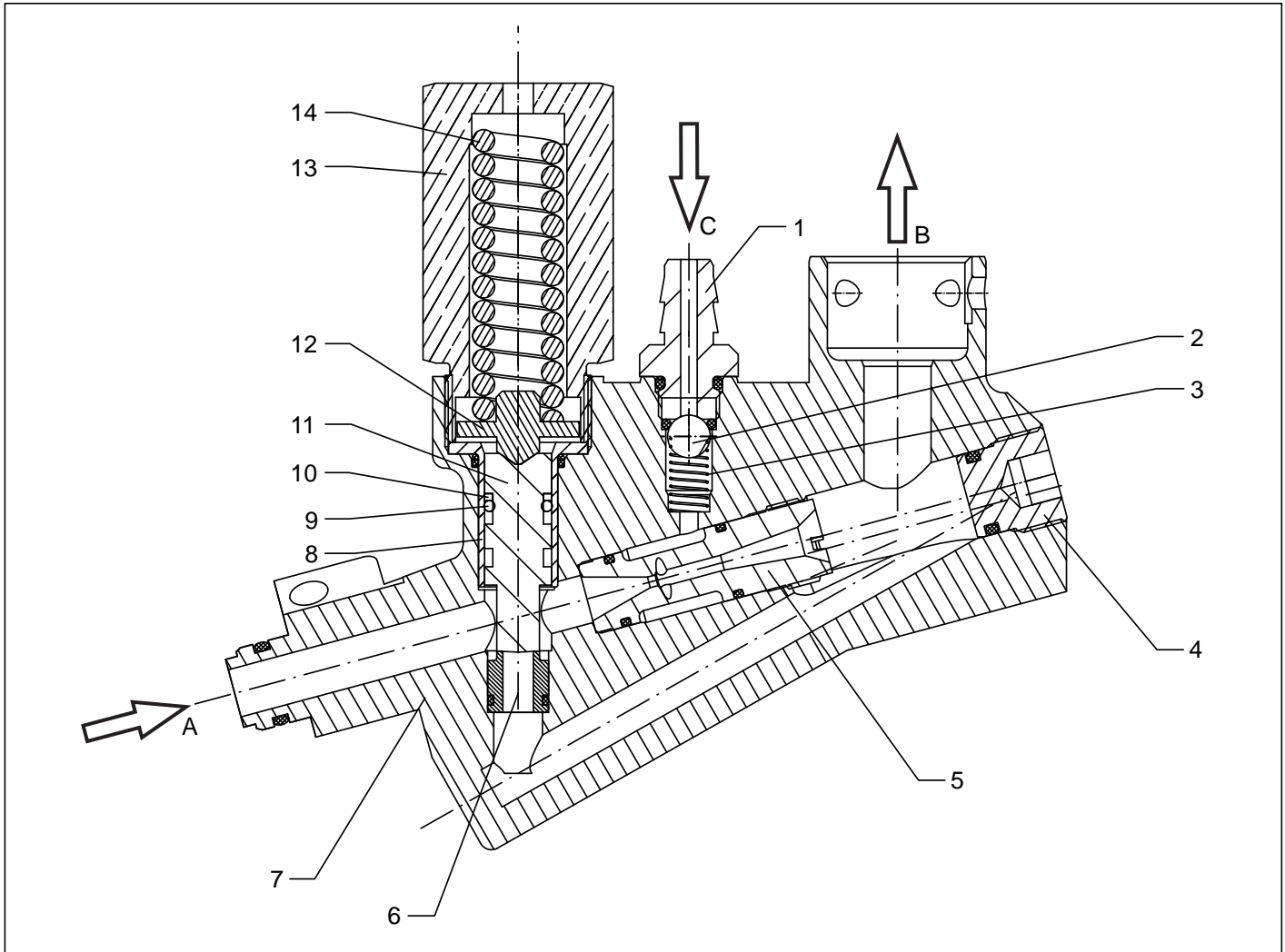

Position	Description	Nm
1	Detergent fitting	12 - 15
2	Sphere	
3	Screw spring	
4	Screwed sealing plug	15 - 17
5	Nozzle insert	1,5 - 2,5
6	Valve seat	
7	Node piece	
8	Liner, replaceable	
9	O ring	
10	Support ring	
11	Piston	
12	Valve bolt	
13	Hexagonal screw	25 - 30
14	Pressure spring	
A	High pressure input	
B	High-pressure outlet	
C	Detergent inlet	

Function

The bypass valve is to keep the pressure loss at a minimum in high pressure operation.

In high pressure operation, the piston opens against the spring force of the pressure spring and lets the water flow to the high pressure outlet via the valve seat. This circumvents the nozzle insert. No detergent is suctioned and the pressure loss remains low.

In low pressure operation, the pressure spring presses the piston onto the valve seat and closes the water flow. The entire water volume flows through the nozzle insert and the detergent is suctioned via the adapter.

7 Basic settings and service procedures

⚠ DANGER

Prior to all work on the appliance, switch off the appliance and pull the power plug.
Shut off water supply.
Drain off water pressure.

7.1 Adjusting the overflow valve

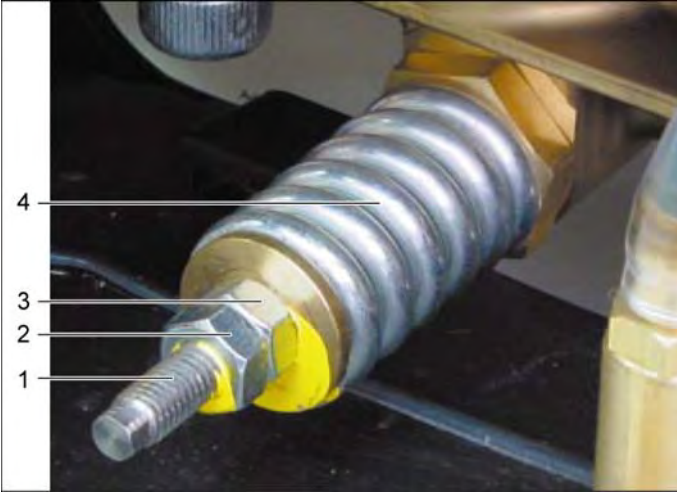

- 1 Overflow valve spindle with hexagon
- 2 Counter-nut
- 3 Rating nut
- 4 Spring

7.2 Trigger gun with servopress pressure regulator

- Connect the test manometer with high-pressure hose and the trigger gun with servopress rotary regulator to the high pressure outlet.
Insert new high-pressure nozzle.
- Turn the servopress rotary regulator to the **smallest** position and let the device run.
- Use the adjustment nut to adjust the tension of the spring so that the overflow valve opening pressure is reached (see technical data).
- Secure the adjustment nut by means of the lock nut.
- Switch the appliance off and remove all pressure by opening the gun.

7.3 Trigger gun standard

- Connect the test manometer with high-pressure hose and trigger gun standard to the high-pressure outlet. Insert new high-pressure nozzle!
- Open the hand spray gun and let the device run.
- Use the adjustment nut to adjust the tension of the spring so that the working pressure reaches full load (see technical data).
- Secure the adjustment nut by means of the lock nut.
- Switch the appliance off and remove all pressure by opening the gun.

Note

The pressure switch is not adjustable.

7.4 Hose drum

Device with hose drum

7.4.1 Remove the hose drum



- 1 High pressure hose
- 2 Safety clip
- 3 Node piece

- ➔ Pull out the safety clip.
- ➔ Pull the high-pressure hose off the connection piece.

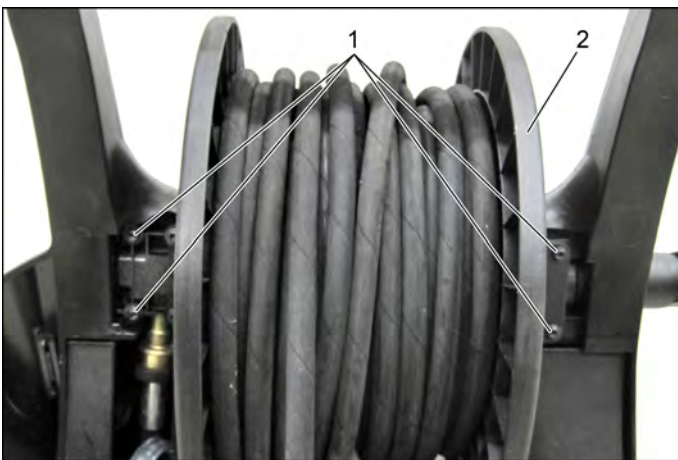

- 1 Screws
- 2 Hose drum

- ➔ Unscrew the screws.
- ➔ Remove the hose reel.

7.4.2 Uninstall / install high-pressure hose



- 1 High pressure hose
- 2 Safety clip
- 3 High pressure outlet
- 4 Hose drum

- ➔ Completely unwind the high pressure hose.
- ➔ Pull out the safety clip.



- 1 high pressure hose
- 2 Washers
- 3 High pressure outlet

➔ Pull the high pressure hose out of the high pressure outlet.

7.4.3 Replace the seal of the rotary grommet

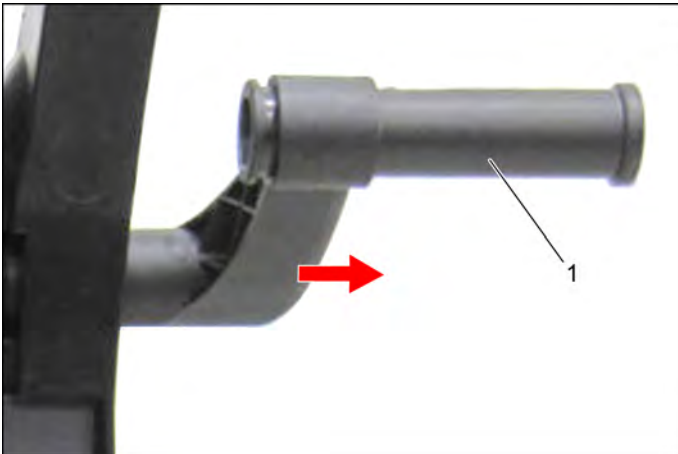

- 1 Crank

➔ Remove the crank from the hose reel straightly.

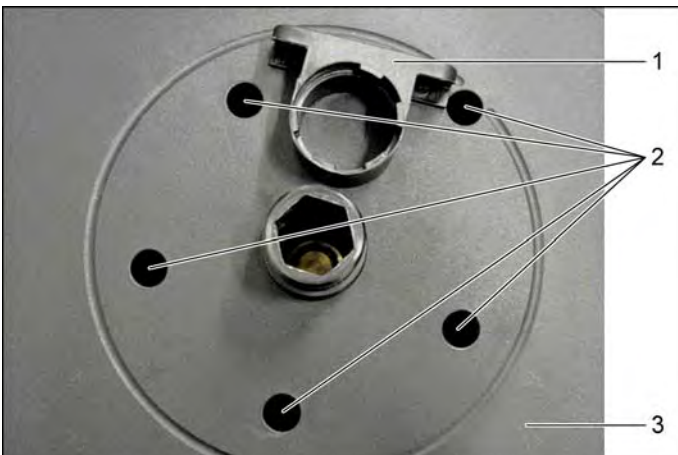

- 1 Holder hose reel
- 2 Screws
- 3 Hose drum

➔ Unscrew the screws.

➔ Remove half shells of the hose reel.

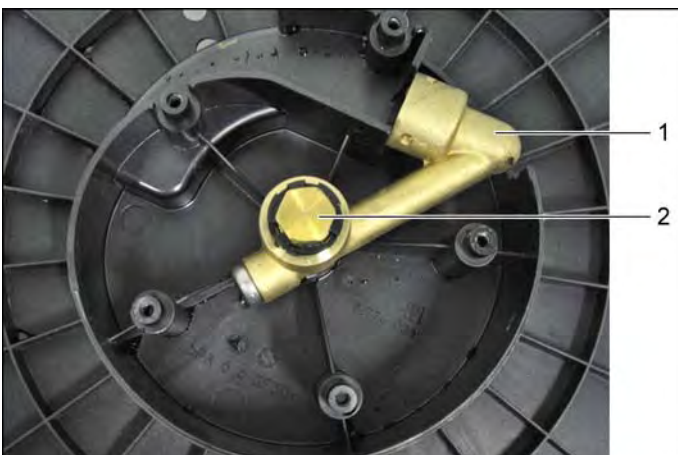

- 1 Node piece
- 2 Seal screw

➔ Remove the seal screw.

➔ Remove the knot and the axle.

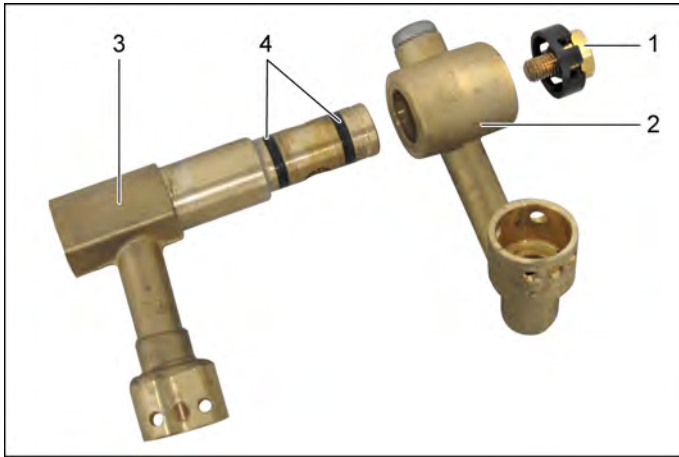

- 1 Seal screw
- 2 Node piece
- 3 Axle
- 4 O rings

- ➔ Remove O-rings.
- ➔ Check axle and connection piece for signs of wear.

Installation information

Replace the O-rings.
Grease the O-rings.

Grease	6.288-088.0
--------	-------------

8 Troubleshooting

Findings	Possible cause	Correction
Appliance is not running	Power supply interrupted	Check connection cable for damages.
		Check mains fuses and mains voltage
	Disturbances in the electrical system	Check / replace transformer.
		Check/replace the fuse.
		Check thermal motor protection switch.
Power switch	Check / replace the contactor.	
Pressure switch	Check/replace the PCB.	
Appliance is not building up pressure	Nozzle soiled	Check/replace the appliance switch.
		Check/replace the pressure switch.
		Set nozzle to "High pressure".
		Clean the nozzle.
		Replace the nozzle.
	Air within the system	Vent appliance.
Insufficient water quantity	Check water supply level (refer to technical data).	
Suction area blocked	Clean the sieve in the water connection.	
	Check all inlet pipes to the pump.	
Pressure interruption	Check the pressure and suction valves for leaks / replace.	
	Check / adjust/ replace overflow valve.	
Device turns on and off while hand spray gun is closed	Tightness of system	Check the trigger gun and the O-rings on the high-pressure hose for leaks / replace.
		Pressure interruption
		Check / replace the pressure retaining valve.
		Check/replace the pressure switch.
		Check / clean / replace the detergent check valve.
		Check the pressure and suction valves for leaks / replace.
Appliance does not switch off when the hand-spray gun is closed	Pressure interruption	Check / adjust/ replace overflow valve.
		Check / replace the pressure retaining valve.
		Check/replace the pressure switch.
Detergent is not being sucked in	Low or no detergent flow	Check / clean detergent suction hose with filter.
		Open or check/clean detergent dosing valve.
		Check / clean / replace the detergent check valve.
		Check / replace nozzle for detergent.
	Replace detergent injector.	
Pump leaky	Water leak between the cylinder head and the piston casing	Check / replace high pressure and low pressure seals.
	Oil leaks between the cylinder head and the piston casing	Replace oil seals.

9 Technical Documentation

Appliance type	Appliance no.	Circuit diagram	Operating instructions	Maintenance log	Spare parts list
HD 10/25 S EU I 400 V / 3~ / 50 Hz	1.286-120.0	0.090-000.0	5.964-882.0	5.950-582.0	5.971-980.0
HD 10/25 SX EU I 400 V / 3~ / 50 Hz	1.286-500.0	0.090-000.0	5.964-882.0	5.950-582.0	5.972-135.0
HD 13/18 S EU I 400 V / 3~ / 50 Hz	1.292-100.0	0.090-000.0	5.964-882.0	5.950-582.0	5.972-157.0
HD 13/18 SX EU I 400 V / 3~ / 50 Hz	1.292-500.0	0.090-000.0	5.964-882.0	5.950-582.0	5.972-159.0

9.1 Technical specifications

		HD 10/25 S HD 10/25 SX	HD 13/18 S HD 13/18 SX
Main Supply			
Voltage	V	400	400
Current type	Hz	3~ 50	
Connected load	kW	9,2	8,8
Protection (slow, char. C)	A	16	25
Type of protection		IPX5	
Maximum allowed net impedance	Ohm	(0,145+j0,090)	
Extension cable 10 m	mm ²	2,5	
Extension cord 30 m	mm ²	4	
Water connection			
Max. feed temperature	°C	60	
Min. feed volume	l/h (l/min)	1200 (20)	1400 (23,3)
Suck height from open container (20 °C)	m	0,5	
Max. feed pressure	MPa (bar)	1 (10)	
Performance data			
Working pressure	MPa (bar)	3...25 (30...250)	3...23 (30...230)
Nozzle size		047	050
Max. operating over-pressure	MPa (bar)	27,5 (275)	25,3 (253)
Flow rate	l/h (l/min)	500...1000 (8,3...16,7)	
Detergent suck in	l/h (l/min)	0...80 (0...1,3)	
Max. recoil force of trigger gun	N	62	68
Values determined as per EN 60335-2-79			
Hand-arm vibration value			
Hand spray gun	m/s ²	<2,5	
Spray lance	m/s ²	<2,5	
Uncertainty K	m/s ²	0,3	
Sound pressure level L _{pA}	dB(A)	72	
Uncertainty K _{pA}	dB(A)	2	
Sound power level L _{WA} + Uncertainty K _{WA}	dB(A)	87	
Fuel			
Amount of oil	l	1,2	
Oil grade		SAE 90	
Dimensions and weights			
Length	mm	560	
Width	mm	500	
Height	mm	1090	
Weight without accessories (SX)	kg	75,5	84 (84,5)
Content detergent tank	l	6	

10 Special tools

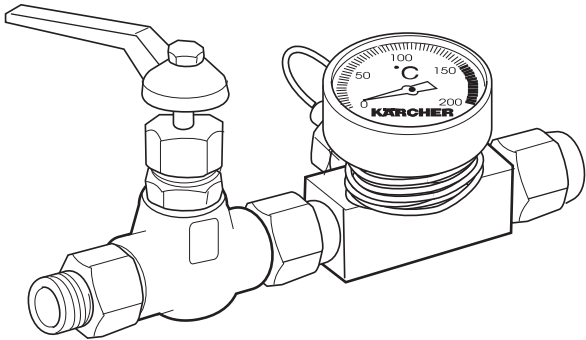
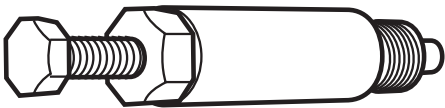
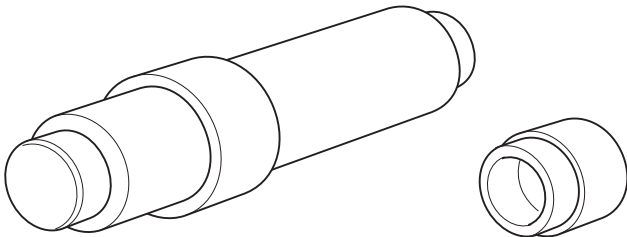
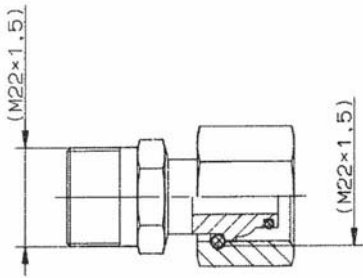
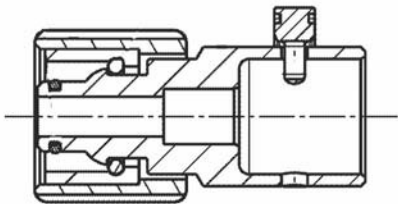
			
Electric measuring appliance	6.803-022.0	Shut-off valve with thermometer	2.901-030.0
			
Puller for swashing plate	4.901-038.0	Installation mandrel oil seal, high-pressure seal Piston diameter 20mm	5.901-055.0
		Installation sleeve, high pressure seal Piston diameter 20 mm and 22 mm	5.901-136.0
		Installation mandrel high pressure gasket Piston diameter 22mm	5.901-064.0
		Installation mandrel oil sealing ring Piston diameter 22mm	5.901-018.0
			
Adapter system 2000, M22x1.5 with extended union nut	4.401-072.0	For hose drum appliances: Adapter M22 (inside) onto 11 mm male coupling	4.424-004.0

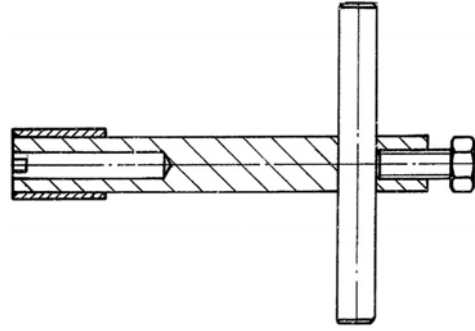
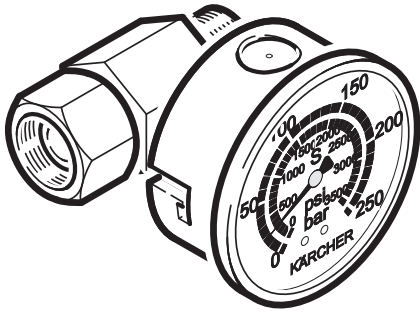

Test manometer for working pressure

4.742-025.0

Installation and removal tools, overflow valve seat

4.901-054.0

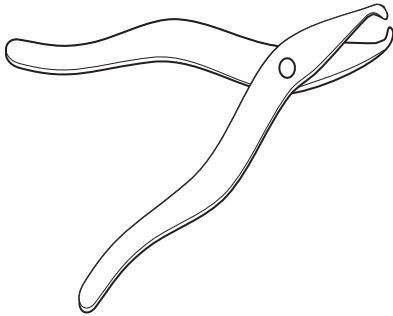

Removal pliers, pressure/suction valves and water sieves

4.901-062.0

11 Circuit diagram

When working on the device, please always use the current circuit diagram in DISIS.

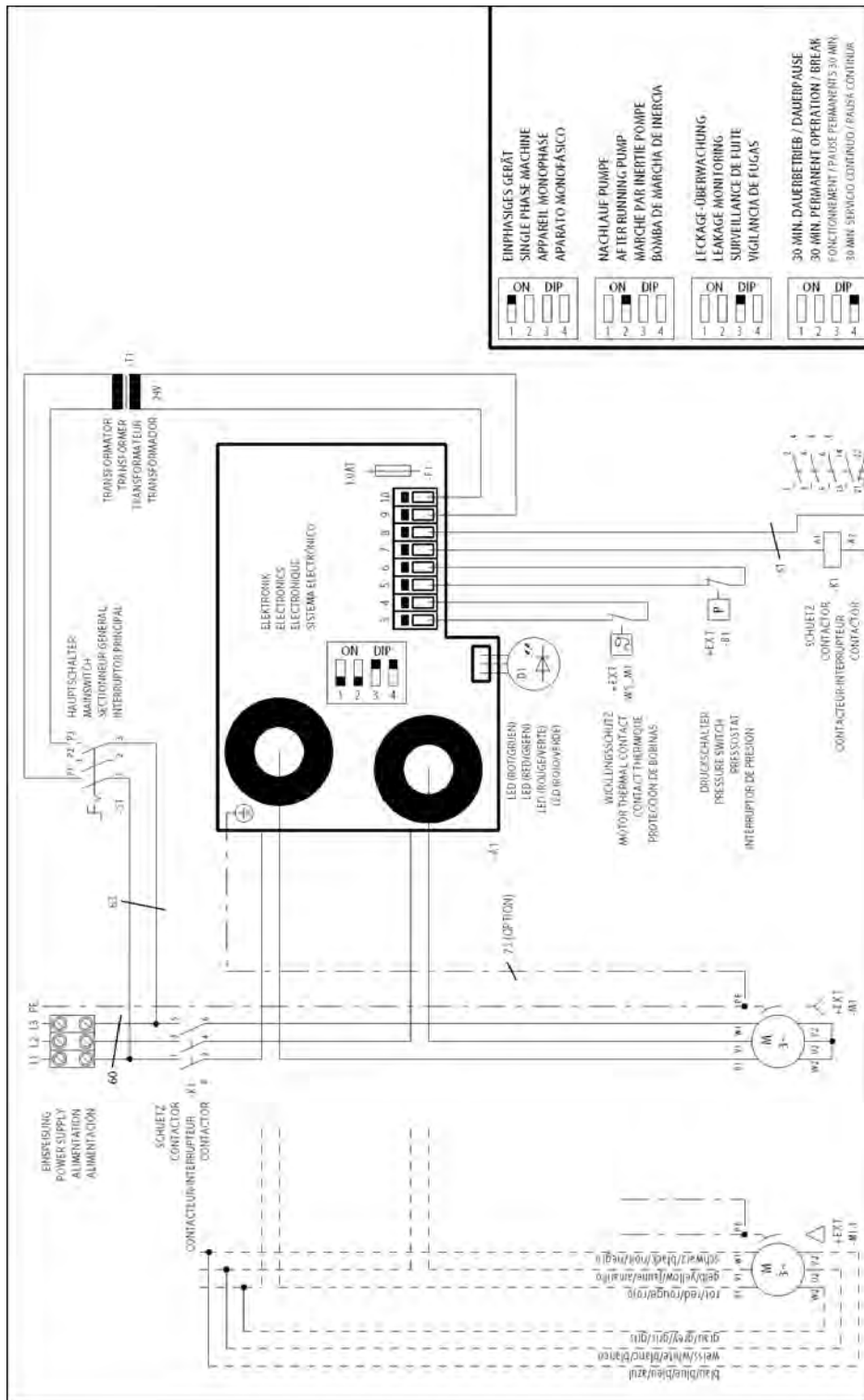

A1	Control chip
B1	Pressure switch
D1	Operating display (LED)
F1	Fuse
K1	Contactor
M1	Motor
Q1/S1	Power switch
Q2	Pressure switch
T1	Transformer
WS_M1	Winding protection contact

12 Torques

Name	Nm
Cylinder head screws	50 - 60
Piston casing	5 - 7
Trigger gun, pressure regulator	40
Screw connection pressure valves	40 - 45
Screw connection pressure switch	15 - 17
Screw connection suction valves	5 - 8
Overflow valve seat	8 - 10
Swash plate	12 + 3
High pressure outlet	6 - 8
Screw connection check valve	40 - 45
Oil drain screw	20 - 25
Motor cover, rear	9 - 10